

FREN KAVRAMA GRUBU

ABG 1.1 SERİSİ

ÖLÇÜLER

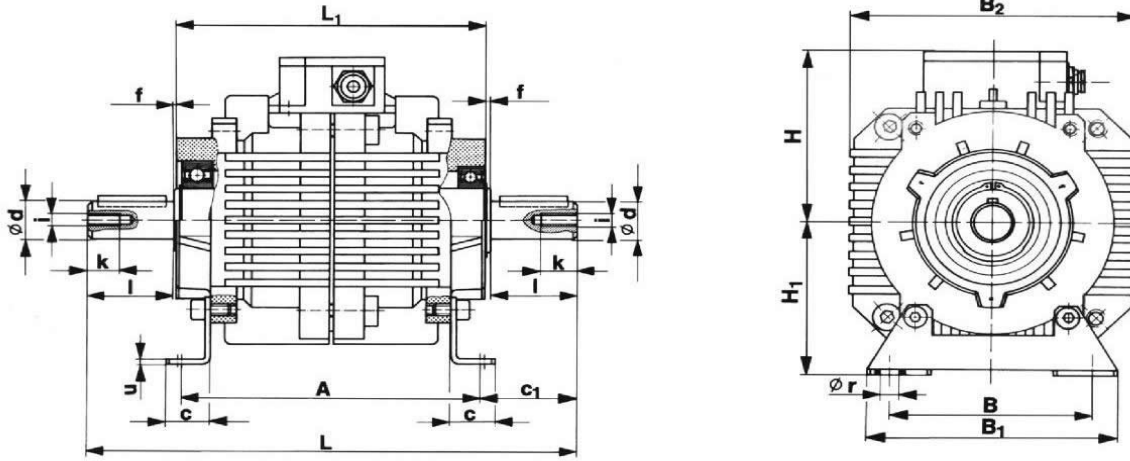

	A	B	B1	B2	c	c1	dk6	f	H	H1	j	k	L	L1	l	r	u
ABG-01	126	75	93	114	19	37	14	1	86	63	M5	12,5	200	138	30	6,6	3
ABG-02	146	95	115	127	22	46,5	19	1	94	80	M6	16	239	157	40	9	3
ABG-03	165	110	136	156	28	57	24	1	106	90	M8	19	279	177	50	11	4
ABG-04	189	120	152	179	28	67	28	1	121	100	M10	22	323	201	60	11	4
ABG-05	230	145	175	230	33	89	38	1	142	132	M12	28	408	246	80	14	5

Ölçüler mm'dir

ELEKTRİK TABLOSU

	Standart Tork (Nm)		Elektrik Gücü (W)		Maximum Hız (d/dk)
	Kavrama	Fren	Kavrama	Fren	
ABG-01	7,5	7,5	20	20	3600
ABG-02	15	15	28	28	3600
ABG-03	30	30	35	35	3600
ABG-04	60	60	45	45	3600
ABG-05	120	120	80	80	3600